



# ROOFING PERMITS

## ROOFING GUIDELINES FOR RESIDENTIAL PROPERTIES



**Minor repairs and routine maintenance** to a roof do not require a permit. Specifically, no more than 25% of a roof can be repaired in any 12 month period without a permit. Any work in excess of this requires a permit.

### When Is a Tear-off Required?

New roof coverings shall not be installed without first removing existing roof coverings where any of the following conditions occur:

1. ...the **existing roof or roof covering is water-soaked** or has deteriorated to the point that the existing covering is not adequate as a base for additional roofing.  
The existing surface must be allowed to dry out completely so as not to trap moisture beneath the new layer of covering. Trapped moisture may cause a rapid deterioration of the new covering material, as well as the existing sheathing. If the existing covering cannot adequately dry out, or has been permanently damaged, it must be removed.
2. ...the **existing roof covering is wood shake, clay, cement, or asbestos-cement tile**.  
These roofing materials do not make an adequate base for new roof coverings, and could prevent the formation of a weather-tight seal, allowing penetration of water, snow, etc. These existing coverings **must always be removed**.
3. ...the **existing roof has two or more layers** of any type of covering. All layers need to be removed to provide a weather-resistant envelope and to safeguard the structural support of the roof.

#### Important Note:

- ◆ TAB-TYPE shingles shall not be installed on roofs below a 2:12 pitch.
- ◆ ROLL ROOFING shall not be installed on any roofs below a 1:12 pitch.
- ◆ Fifteen pound felt paper is required on all roofs. Two layers of fifteen pound felt paper are required on all roofs below a 4:12 pitch.
- ◆ FLASHING must be to code.
- ◆ An ICE AND SNOW SHIELD is required on all roofs.

## Typical Ice & Snow Shield Application

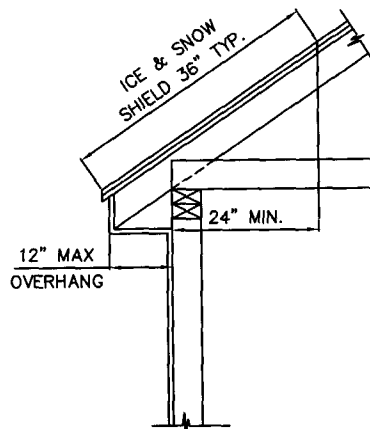

## Venting Attic Spaces

- If attic is vented by **static (can) vents only**, every 150 square feet of attic space requires one square foot of attic ventilation.
- If attic is vented by **ridge or static and soffit vents**, one square foot of ventilation for every 300 square feet of attic space is required.
- A **ridge vent** must be installed per manufacturer's specifications, and must utilize cross ventilation.

## The Permit Process

- ◆ A roofing permit can generally be issued while you wait.
- ◆ You will need to fill out an application, along with a copy of your driver's license and pay the appropriate fee.
- ◆ If you hire a contractor to do the job, you should have the contractor obtain the permit. Before the contractor starts work you should ask to see a copy of the permit.
- ◆ You may obtain the permit as a homeowner and have friends and family help you with the project, by you CANNOT hire a contractor that is unlicensed to do the work.
- ◆ After the work is complete, call the building department for a final inspection. If you give the building department permission to enter the rear yard and there are no dogs in the yard, you do not have to be home for the inspection.
- ◆ The person that obtains the permit is legally responsible for the work.
- ◆ To arrange an inspection, call the Oak Park Department of Technical and Planning Services at (248) 691-7450.

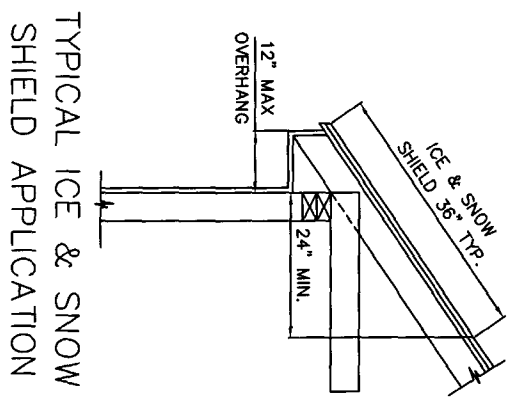

TYPICAL ICE & SNOW SHIELD APPLICATION